

MEEN 2250:
Computer Aided Engineering

Mondays and Wednesdays
2:00 – 3:20 pm NTDP F175

Lecture 04

Dimensions and Tolerances

Bora Yuce

Teaching Assistant, Mechanical and Energy Engineering

© 2009 Bora Yuce and Dr. Matthew J. Traum

Over-dimensioned Part

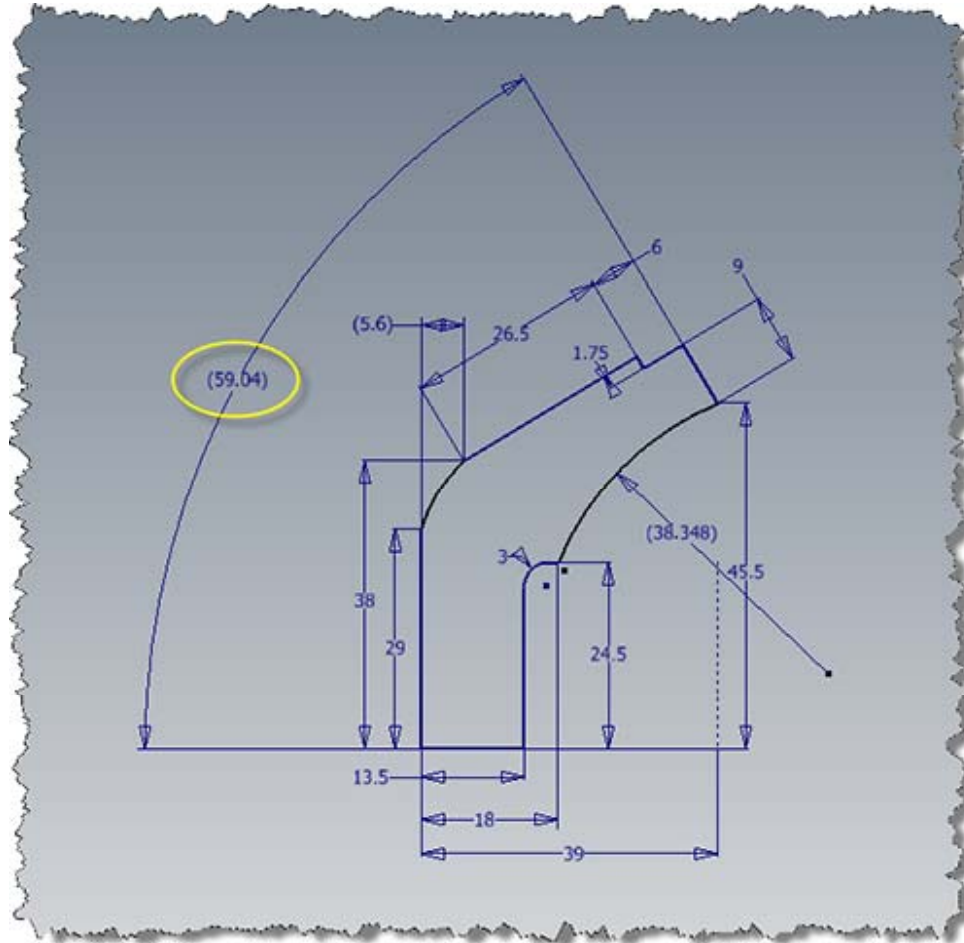

Dimension



Numerical value that defines a face, shape or feature

Basic Dimension

- Stresses that the dimension is the theoretical exact size. There is no room for tolerance.



Reference Dimension

- This is not a defining dimension, but rather used as a reference.



Dimension Line

- Shows extent and direction of a dimension



Arrow

- Points to what is dimensioned



Extension Line

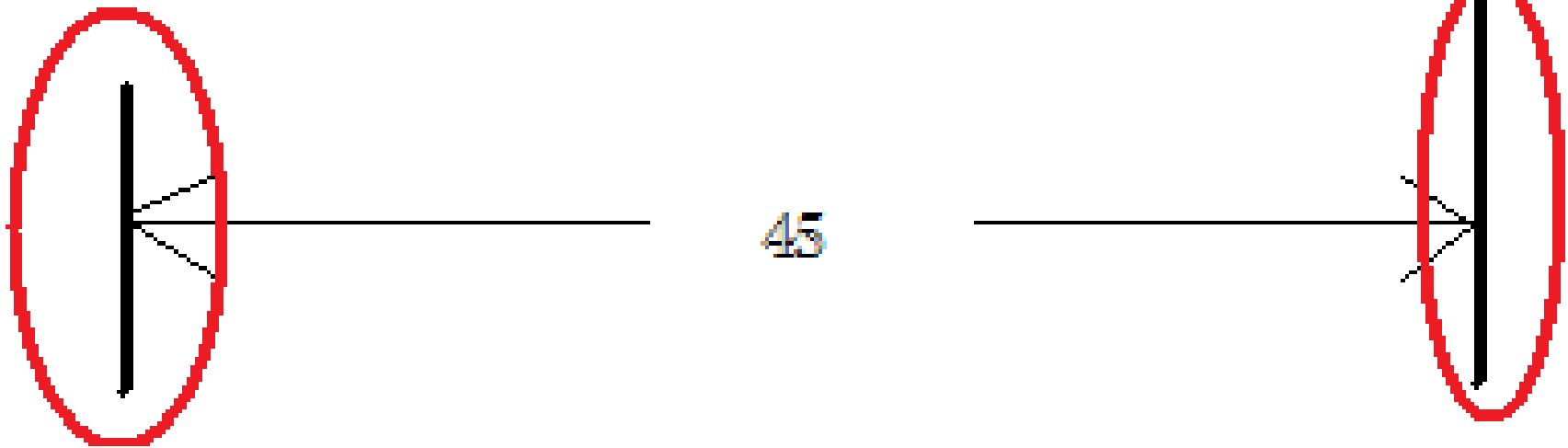

Leader Line

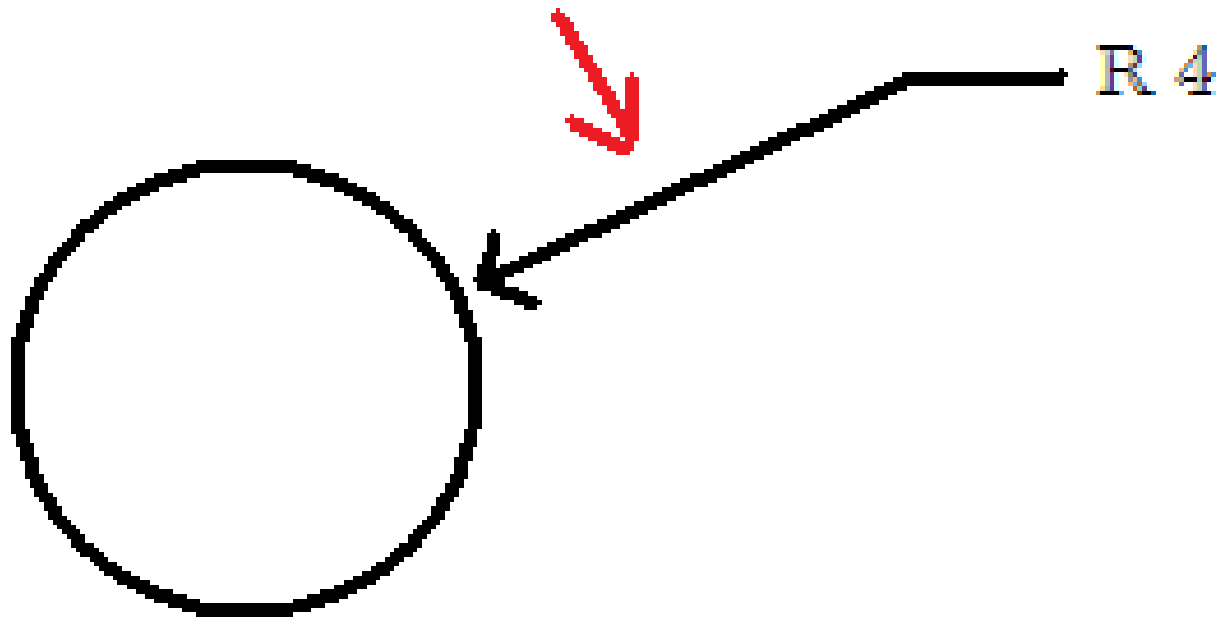

+ - Dimentions

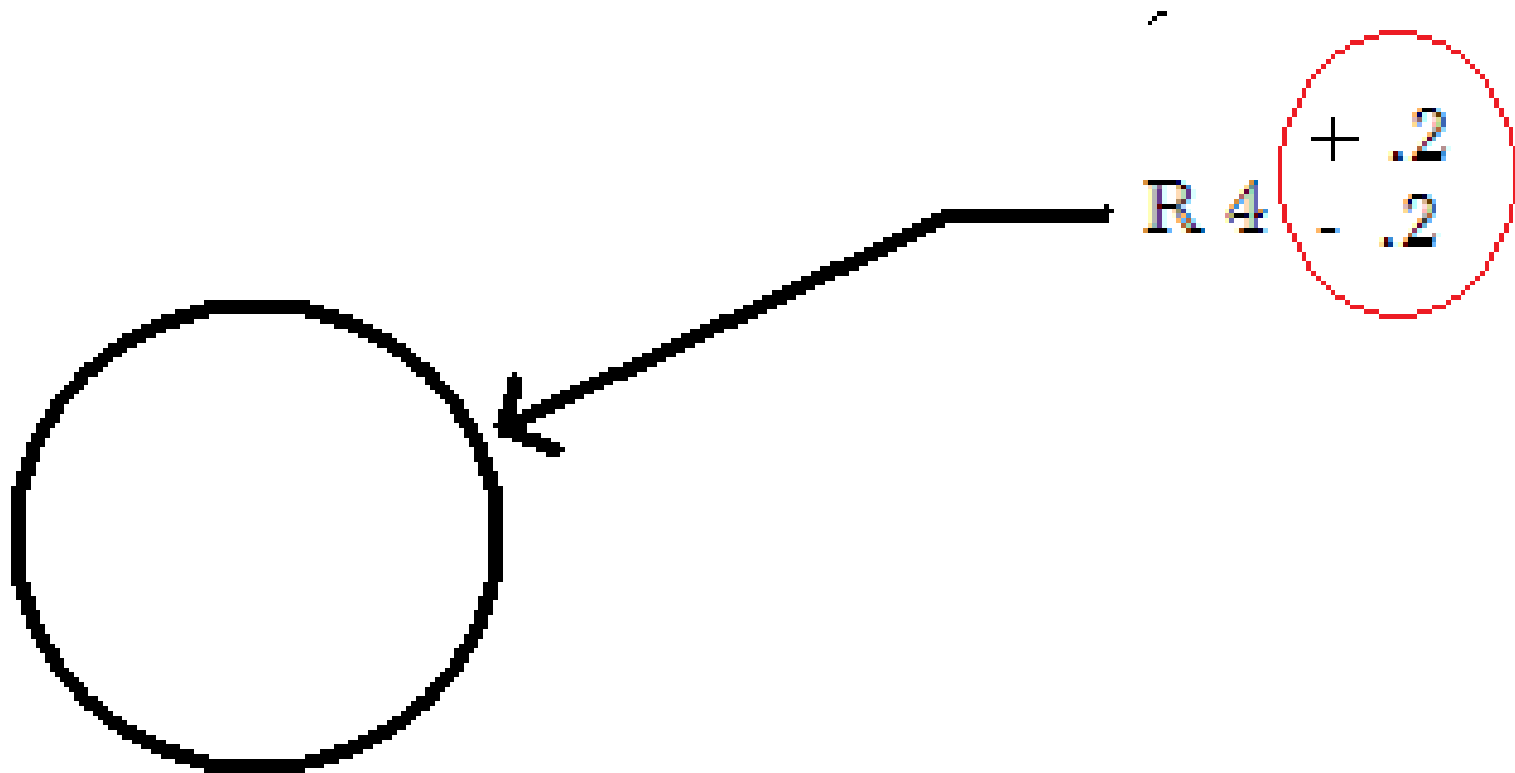

Diameter Symbol

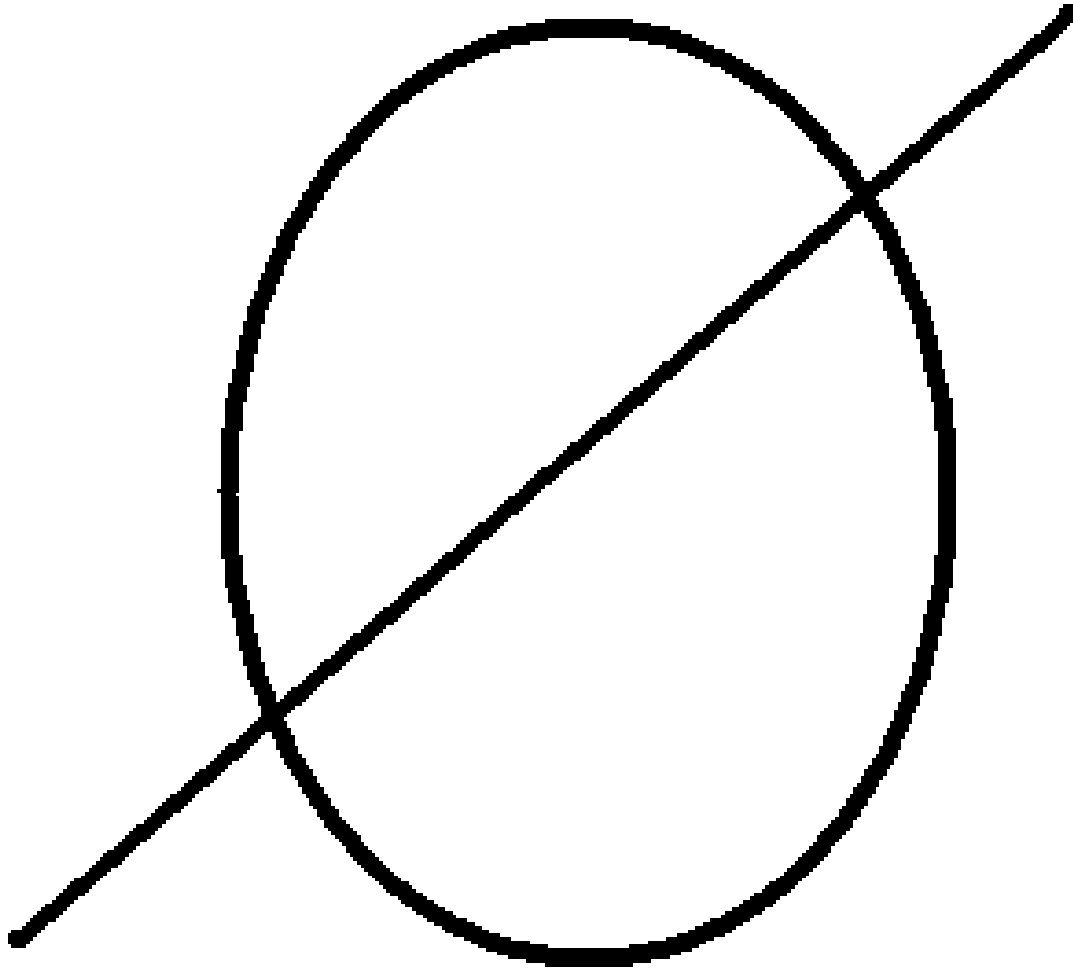

Tolerance

- The amount of wiggle room you have for an object. This is written out on the page rather than shown on the object.

Make Dimensions as Easy as Possible to Interpret



IF it is hard to draw the dimensions

- YOU ARE DOING SOME THING WRONG!



Staggered

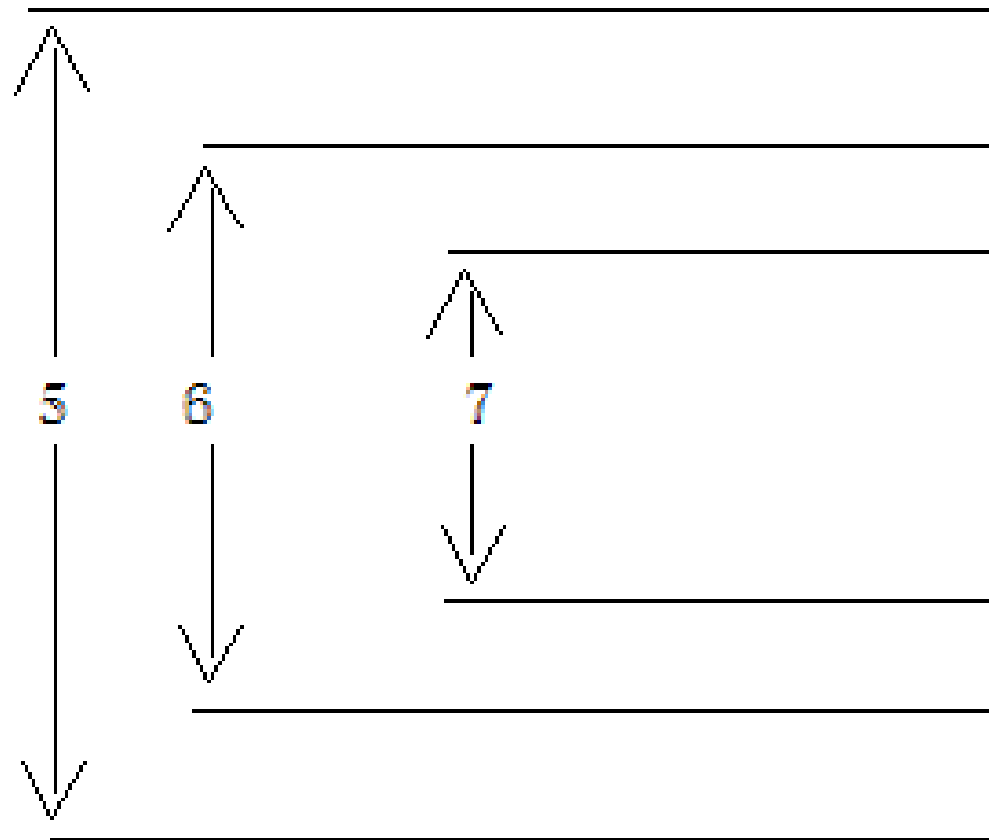

Group Dimension

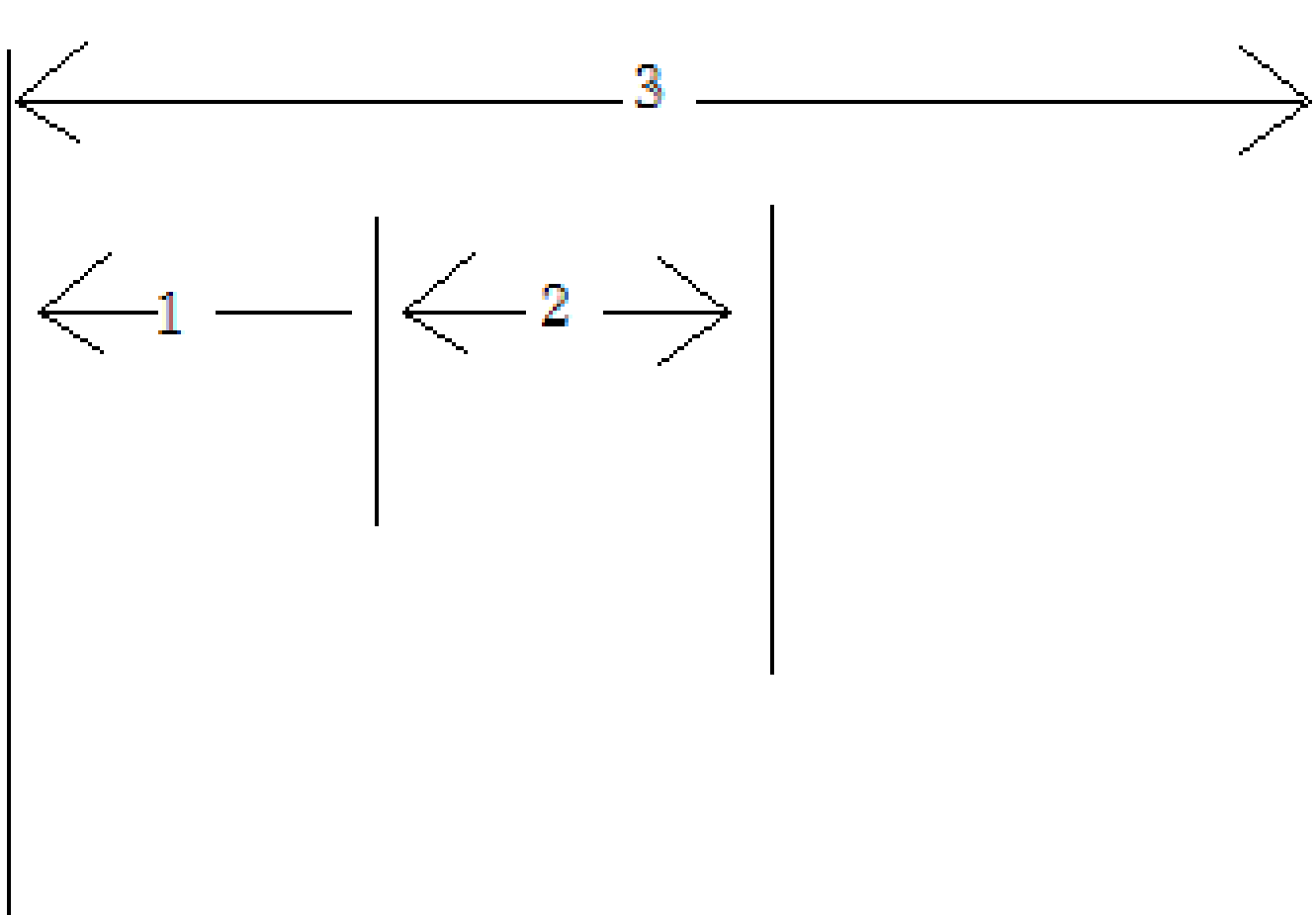

Angle

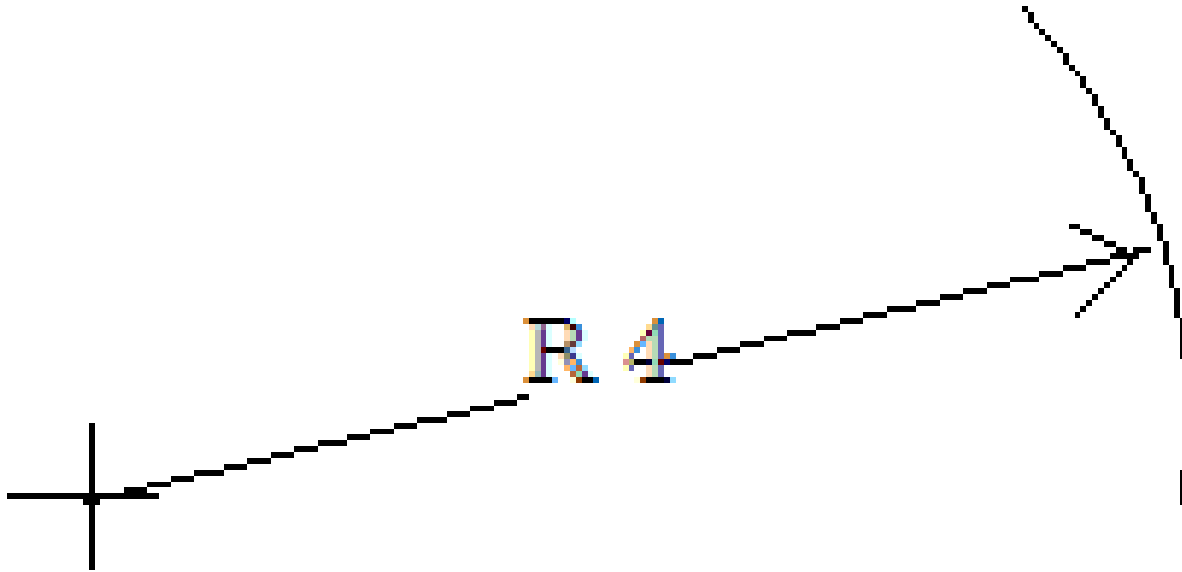

Do Not

- Cross extension lines with dimension lines
- Over dimension
- Write dimension inside object
- Write out dimensions repetitively

Tolerance

- Clearance fit-Always have space between them.
- Interference fit-Always will be pushing against each other
- Transition fit-Could be jammed in, could slide in. does

Thread Notes



+



=

This

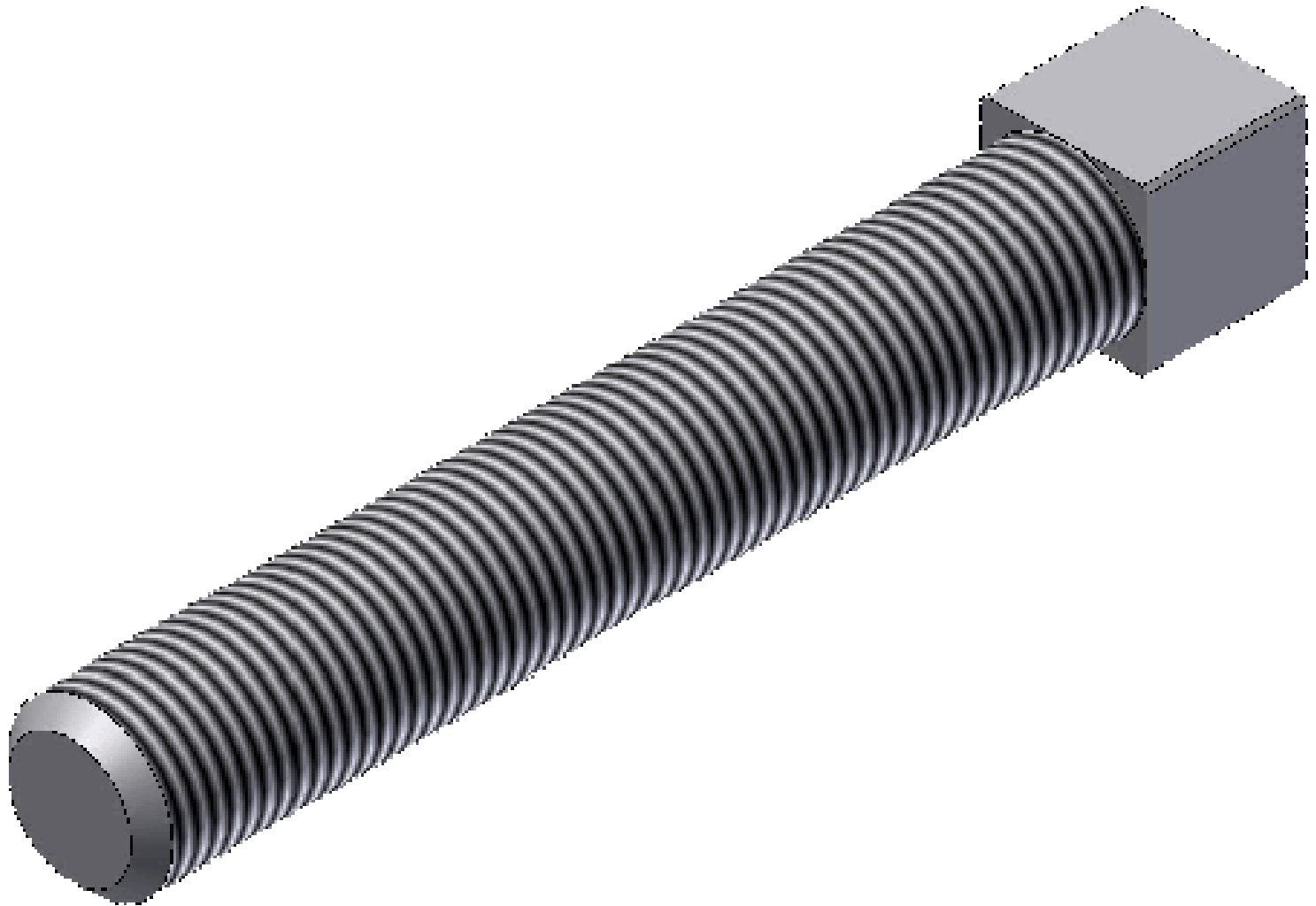

Or

.250 - 20 - UNC - 2A - LH

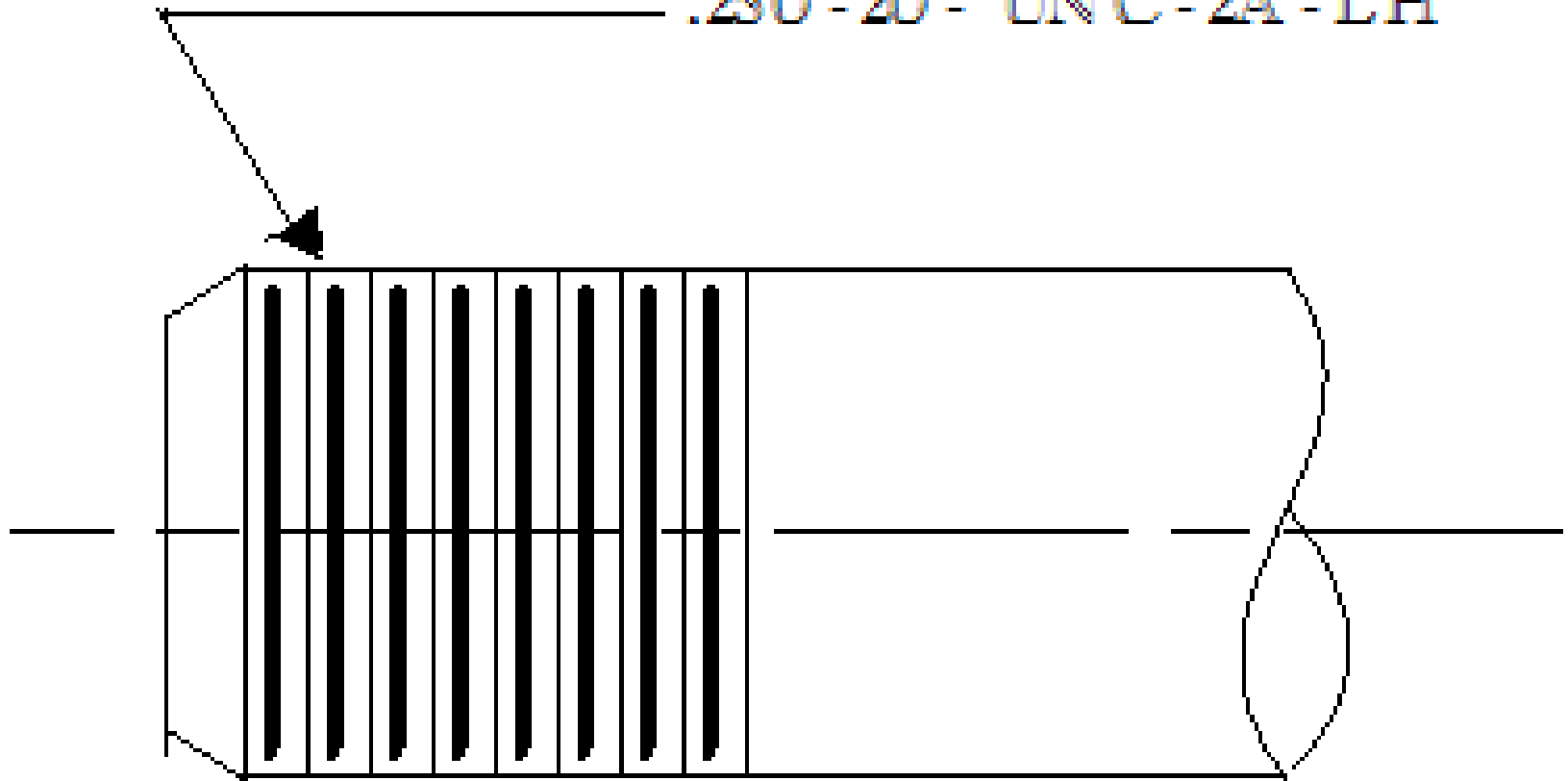

Dissecting those numbers

Major diameter

Class of fit

Form

Direction of
threads

.250-20 UNC-2A-LH

Threads/inch

Series

Internal

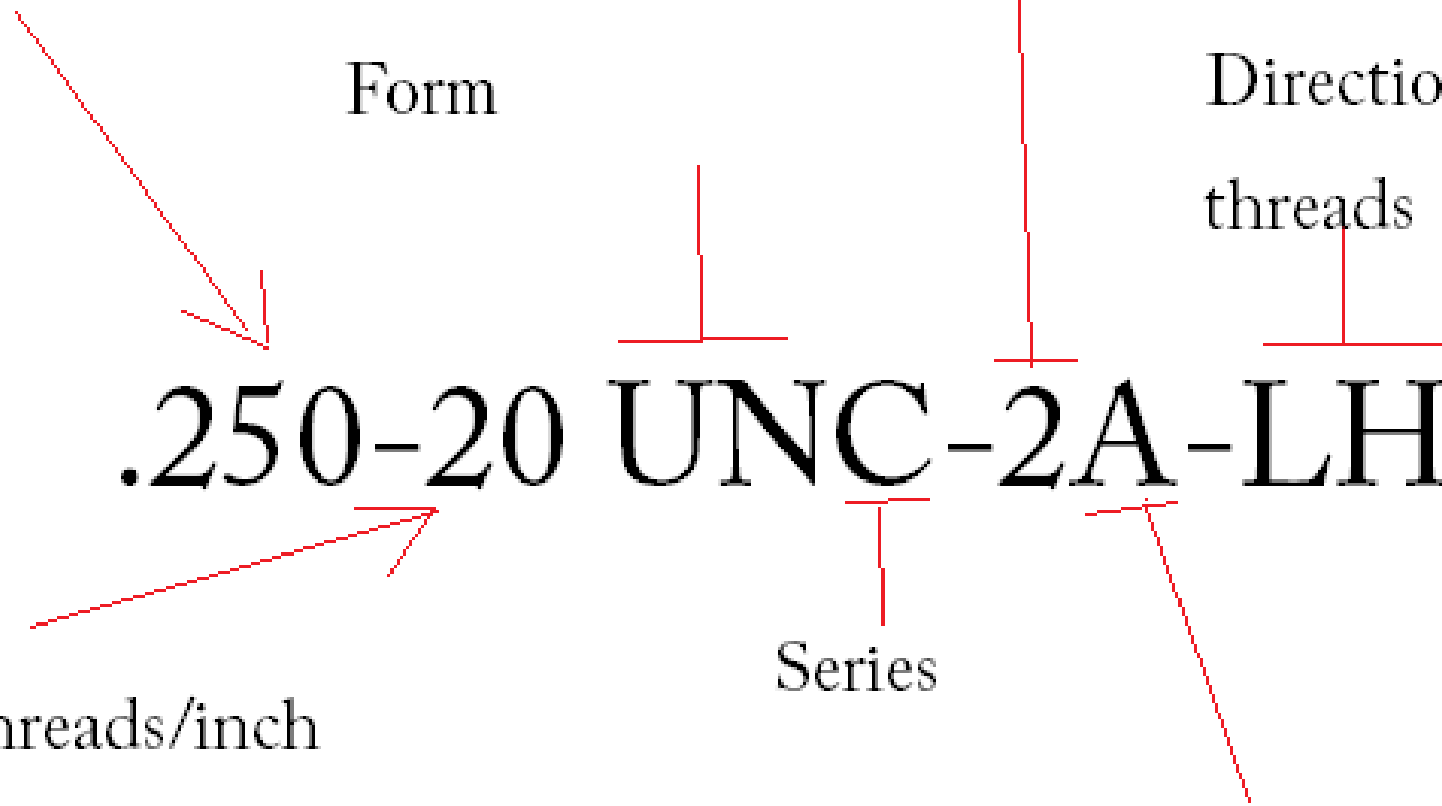

MEEN 2250:
Computer Aided Engineering

Mondays and Wednesdays
2:00 – 3:20 pm NTDP F175

Lecture 04

Dimensions and Tolerances

Bora Yuce

Teaching Assistant, Mechanical and Energy Engineering

© 2009 Bora Yuce and Dr. Matthew J. Traum